



SEE. ADAPT. THRIVE.

# 2010 AMT REGIONAL MEETINGS

# 2010 Market Data and Analysis

Patrick McGibbon

Vice President – Strategic  
Information & Research

SEE. ADAPT. THRIVE.



# Data & Analysis

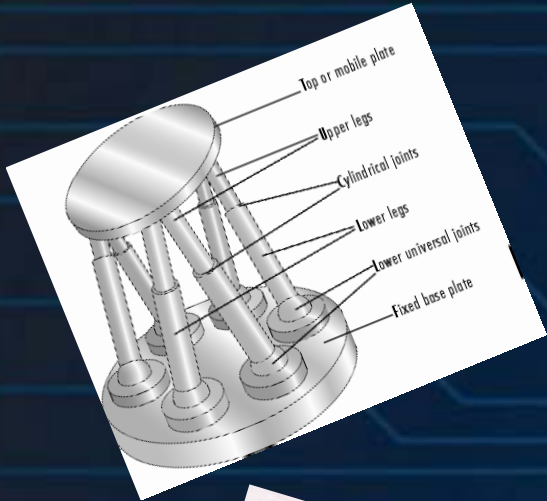

USMTC Monthly Product Mix Orders - 2009

Monthly Product Mix Orders Report

		Jan	Feb	Mar	Apr	May	Jun	Jul	Aug	Sep	Oct	Nov	2009
MACHINING C ENDS VEET CNC, WINDO & CARBIDE/FLYER FRAME IN TABLE, 2041.281	Open Lines	10	4	11	10	11	9	12	10	12	11	11	111
	Cancellations	0	0	0	0	0	0	0	0	0	0	0	0
	Net Lines	10	4	11	10	11	9	12	10	12	11	11	111
	Net Order \$	\$84,174	\$21,210	\$1,227,844	\$767,204	\$46,275	\$671,210	\$1,027,051	\$780,540	\$417,640	\$1,110,000	\$8,111,000	\$8,111,000
MACHINING C ENDS VEET CNC, WINDO & CARBIDE/FLYER FRAME IN TABLE, OVER 15" & UNDER 18" - 2041.282	Open Lines	20	20	20	20	20	20	20	20	20	20	20	211
	Cancellations	1	2	2	2	2	2	2	2	2	2	2	2
	Net Lines	19	18	18	18	18	18	18	18	18	18	18	209
	Net Order \$	\$1,202,840	\$1,277,500	\$2,228,224	\$1,794,284	\$2,242,000	\$1,287,000	\$846,140	\$1,218,240	\$1,198,000	\$2,244,240	\$1,100,000	\$12,244,270
MACHINING C ENDS VEET CNC, WINDO & CARBIDE/FLYER FRAME IN TABLE, OVER 18" & UNDER 24" - 2041.284	Open Lines	60	60	60	60	60	60	60	60	60	60	60	611
	Cancellations	60	60	60	60	60	60	60	60	60	60	60	60
	Net Lines	0	0	0	0	0	0	0	0	0	0	0	0
	Net Order \$	\$8,022,000	\$8,118,000	\$8,894,200	\$2,178,220	\$2,200,000	\$2,268,000	\$8,896,870	\$4,943,524	\$8,826,271	\$1,283,200	\$8,798,000	\$81,227,010
MACHINING C ENDS VEET CNC, WINDO & CARBIDE/FLYER FRAME IN TABLE, UNDER 15" - 2041.283	Open Lines	20	20	20	20	20	20	20	20	20	20	20	211
	Cancellations	0	0	0	0	0	0	0	0	0	0	0	0
	Net Lines	20	20	20	20	20	20	20	20	20	20	20	211
	Net Order \$	\$12,110,000	\$12,294,000	\$19,940,000	\$17,890,000	\$17,890,000	\$17,890,000	\$12,176,400	\$18,891,100	\$19,241,100	\$19,241,100	\$18,891,100	\$188,811,700
MACHINING C ENDS VEET CNC, WINDO & CARBIDE/FLYER FRAME IN TABLE, OVER 24" & UNDER 42" - 2041.285	Open Lines	10	10	10	10	10	10	10	10	10	10	10	111
	Cancellations	0	0	0	0	0	0	0	0	0	0	0	0
	Net Lines	10	10	10	10	10	10	10	10	10	10	10	111
	Net Order \$	\$1,200,000	\$1,200,000	\$7,212,000	\$8,212,000	\$8,212,000	\$8,212,000	\$8,212,000	\$8,212,000	\$8,212,000	\$8,212,000	\$8,212,000	\$84,212,000

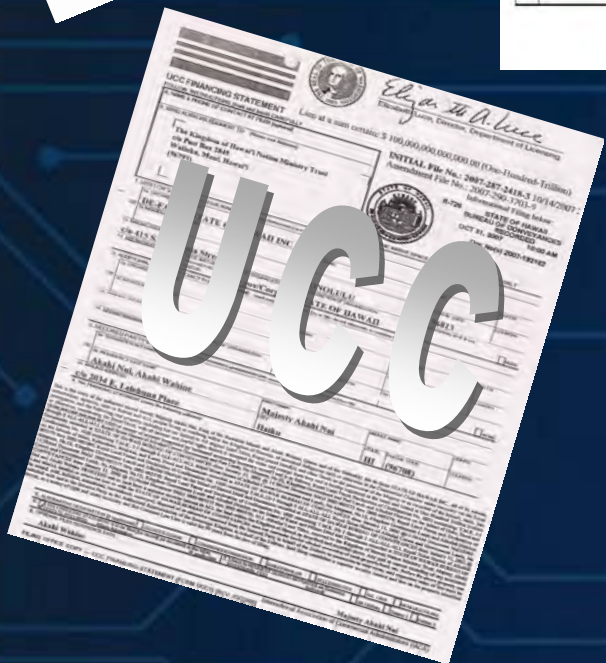
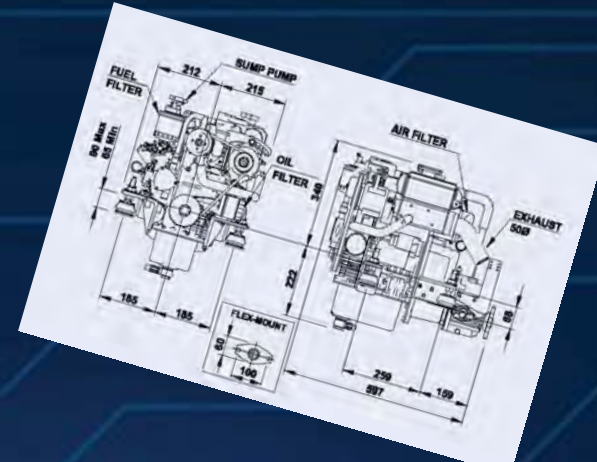

# OEF: Issues

- China/India Robust
- Credit Available
- Policy Normalization
- Investment Outlook



# Recovery Indicators

- Capacity Utilization
- Purchasing Mngrs Index
- AAA Bond Rating
- Mfrd Durables Shipments
- Orders Primary Metals
- Baltic Dry Index
- Housing Starts
- Consumer Confidence
- Restaurant Barometer

# Mfg Technology Orders

- Capacity Utilization
- Purchasing Mngrs Index
- AAA Bond Rating
- Mfd Durables Shipments
- Orders Primary Metals
- Baltic Dry Index
- Housing Starts
- Consumer Confidence
- Restaurant Barometer

# Sophisticated



# Simplify



# Developing MI Toolbox



# Statistical Toolbox Development



Calculate  
Market Share

→

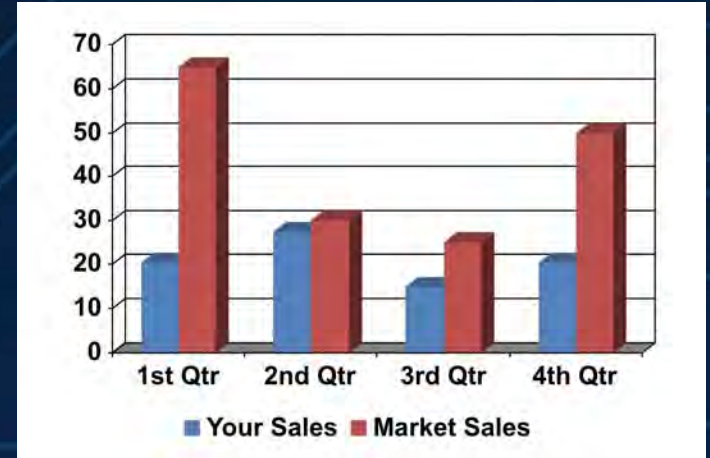

Visualize  
Market  
Opportunities

→



Translating mountains  
of AMT data into  
**ANSWERS!**

→  
Early Warning  
Forecasts

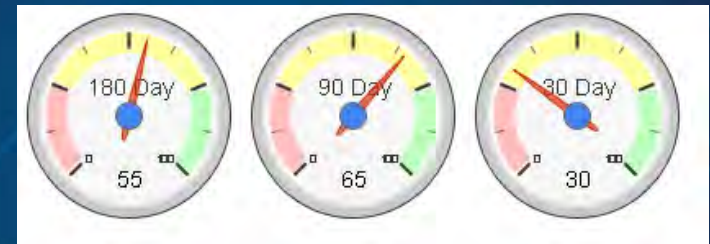

# The Dashboard Approach

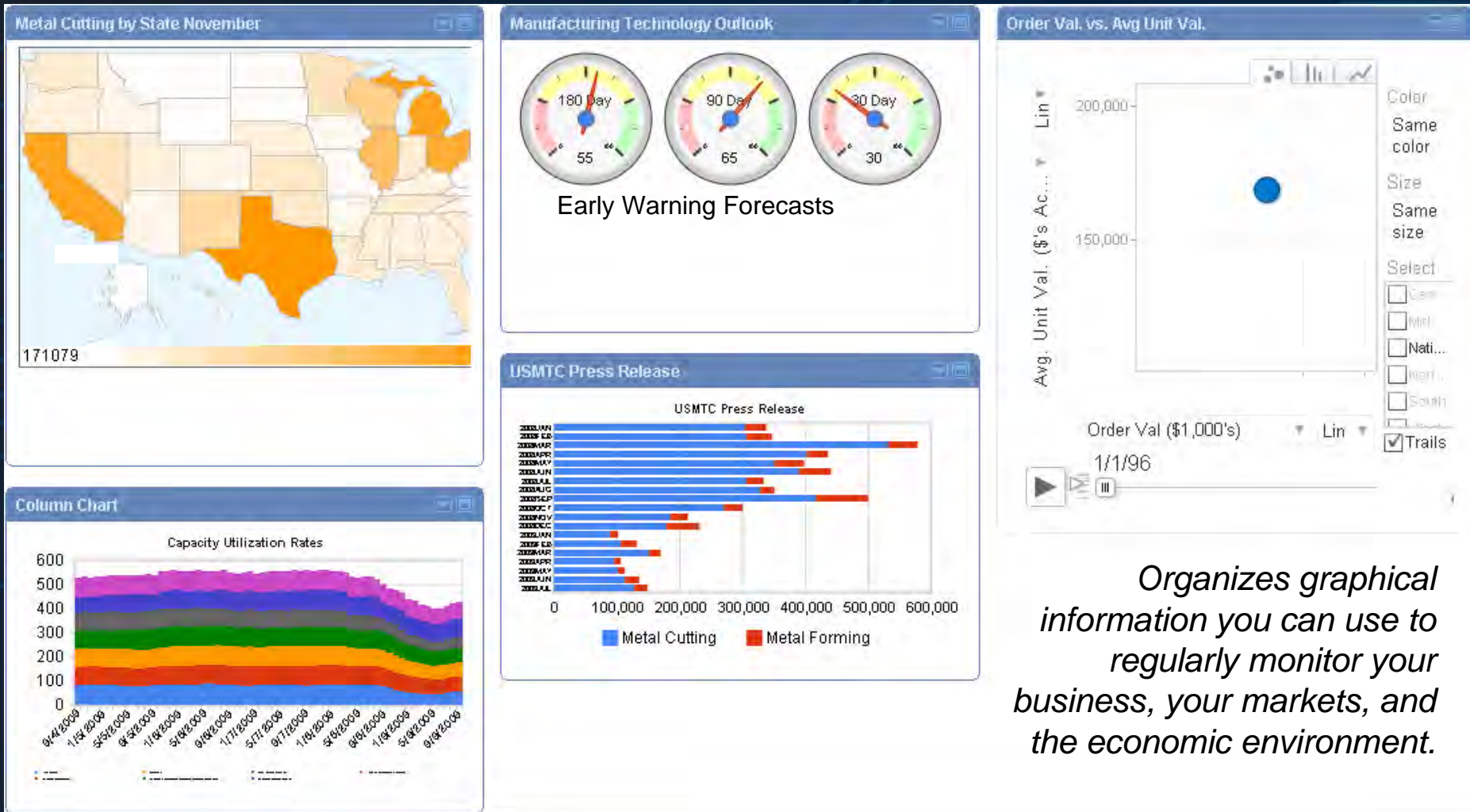

*Organizes graphical information you can use to regularly monitor your business, your markets, and the economic environment.*

# USMTC Illustrated

Uses USMTC data downloads to Excel to produce your market share statistics.

- By product category
- By State
- By Territory (Coming Soon)

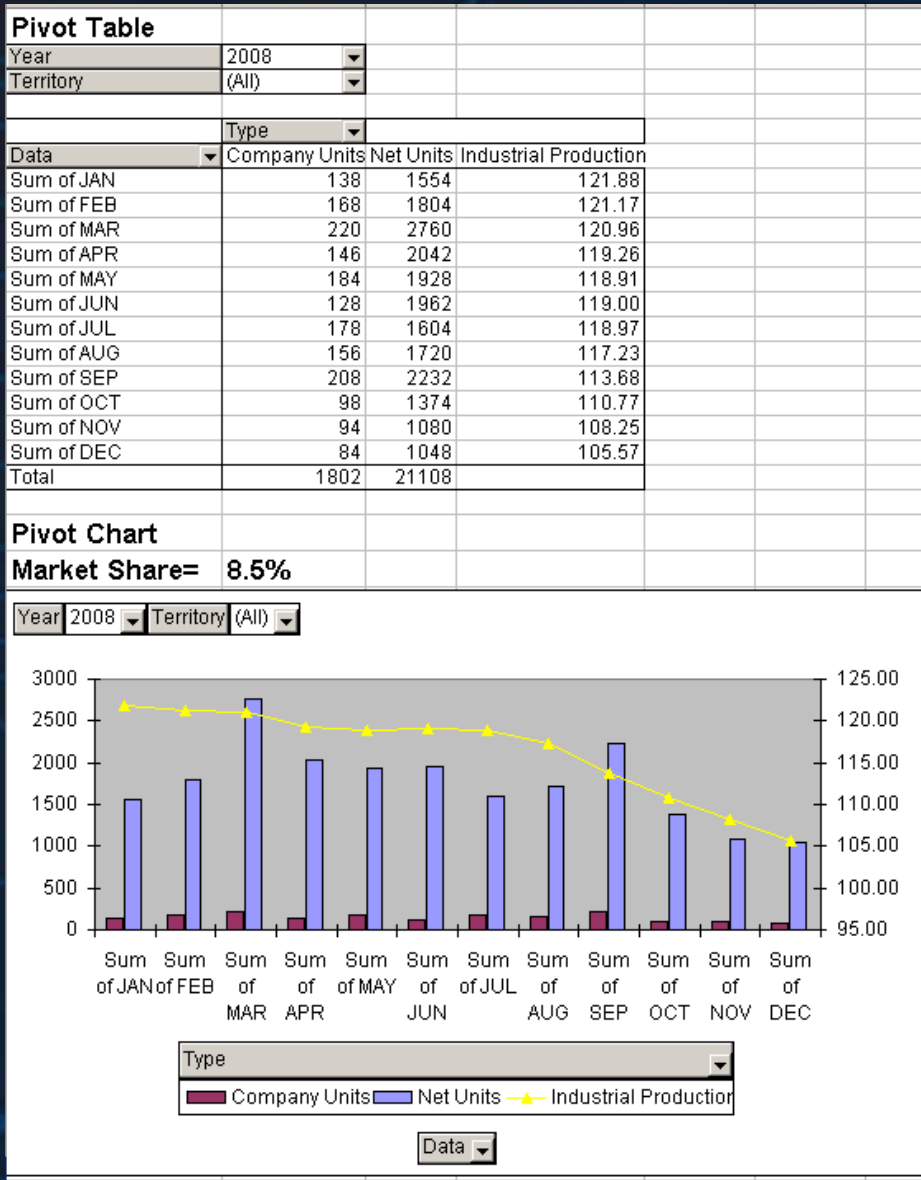

# AMT's MIS Dashboard

## ➤ How Does It Work?

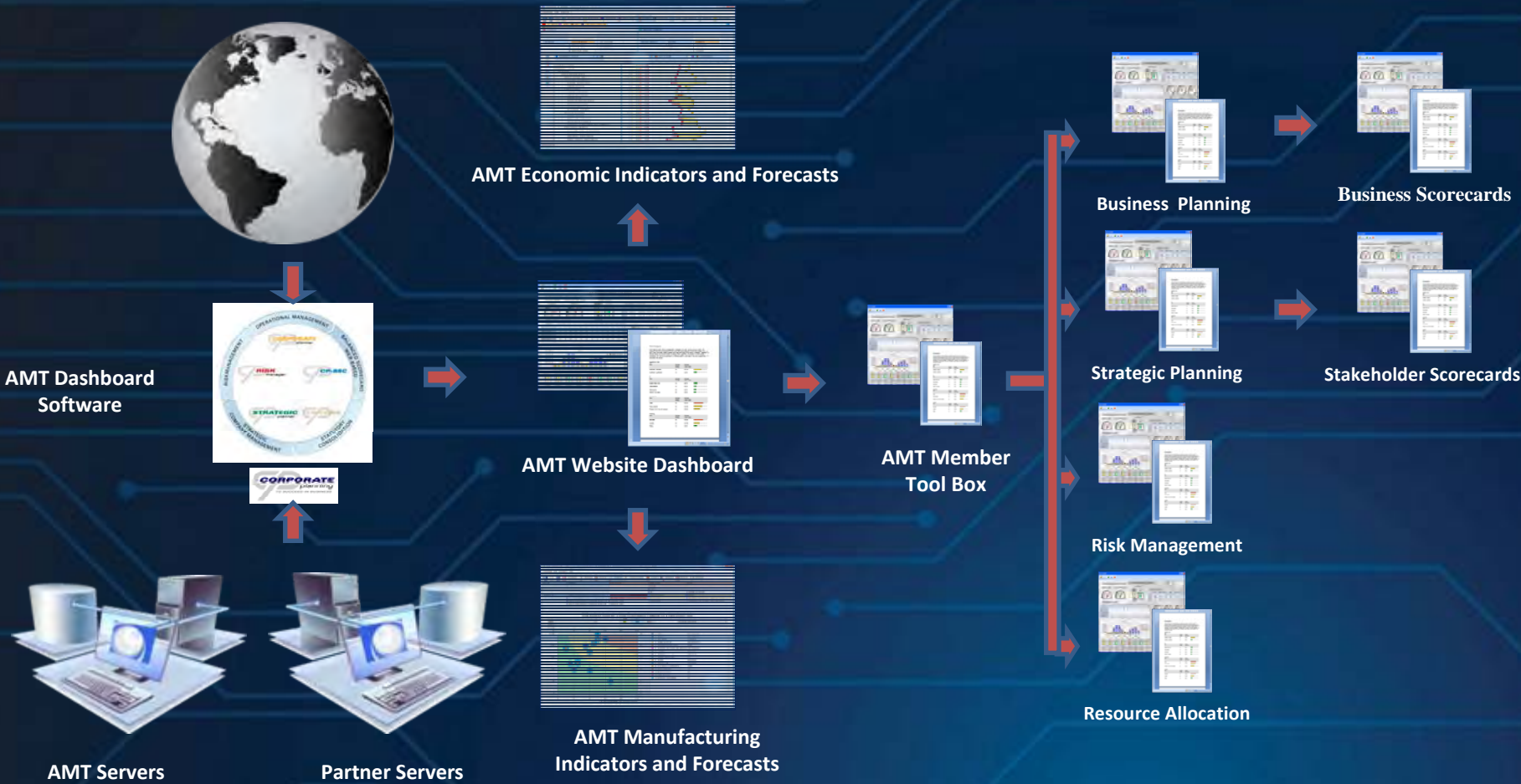

# AMT's MIS Dashboard

➤ What Is The User Interface Concept?

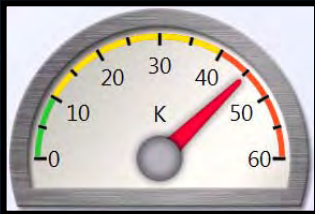

Key Economic Indicators



Economy Trend



Key Manufacturing Indicators



Manufacturing Trend

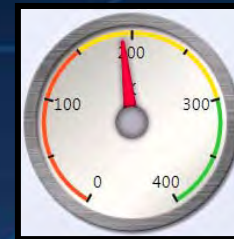

Machine Tool Investment Index

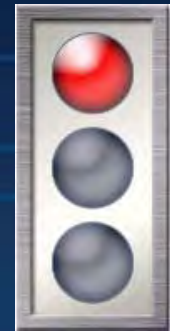

# AMT's MIS Dashboard

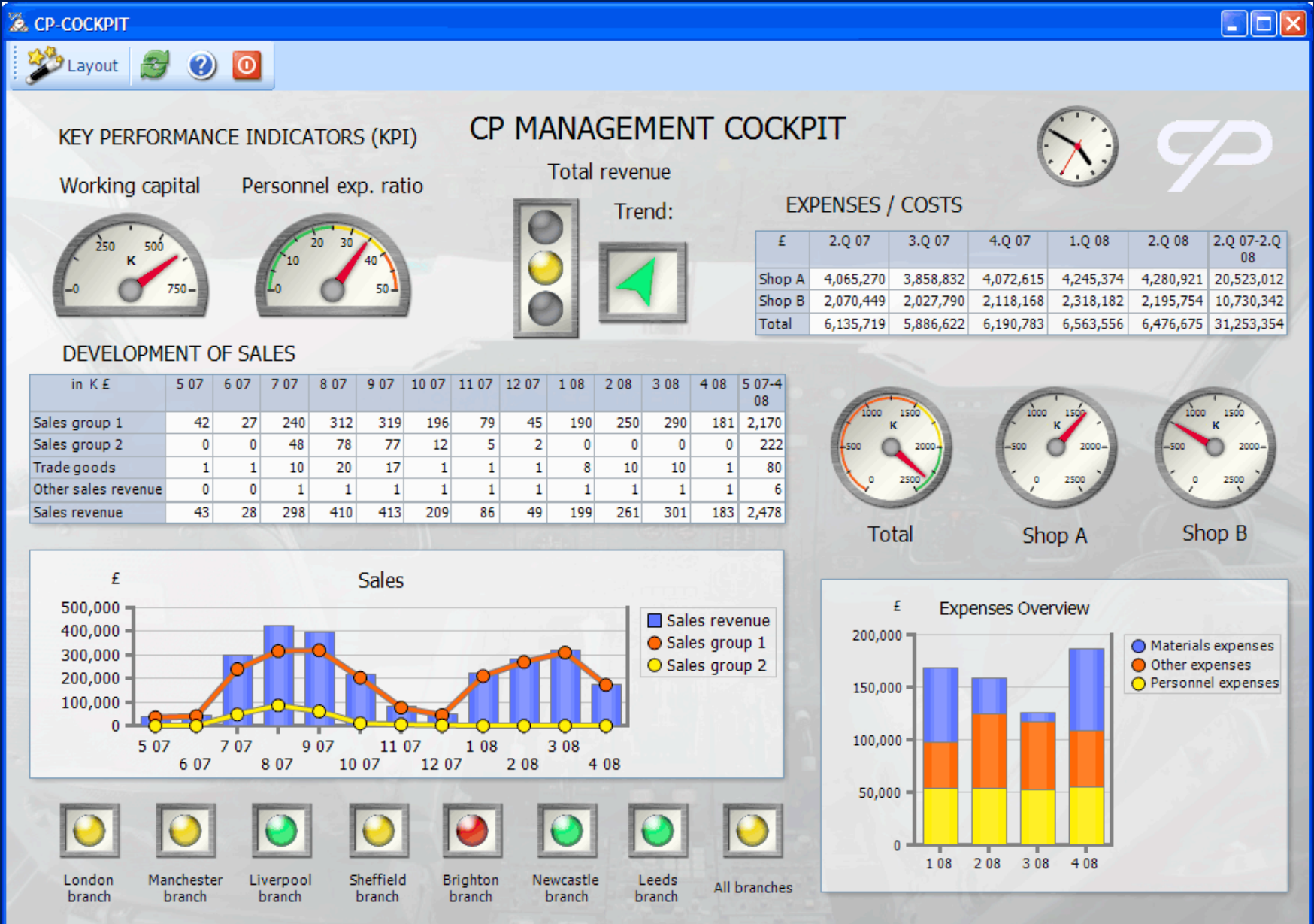



*If you can't  
simplify*  
**REORGANIZE!**

# Why?

## *Trade Opportunities*



## Globaline



Current Industrial News  
*June 6, 2008*

# Sell Your Product

Home | [About AMT](#) | [Member Directory](#) | [Store](#) | [Contact Us](#) | [Logout](#) | [Help](#) Search our site:  [GO](#) [Adv. Search](#) | [Tags](#)



**AMT**  
The Association For  
Manufacturing Technology  
*Over 100 Years of Building Global Productivity*  
[www.AMTonline.org](http://www.AMTonline.org)



Technology & Standards | [Sell Your Product](#) | [Services For Your Business](#) | [Research Your Markets](#) | [Advocacy](#) | [Calendar](#) | [Newsroom](#)

[Sell Your Product](#)

[Latest Announcements](#)

[Sell Now](#)

[On the Horizon](#)

[Scuttlebutt](#)

[Current Funding Opportunities](#)

---

[Kathryn Fritz](#)

[Logout](#)

[Site Maintenance](#)

---

[Groups](#)

[2009 GFMC Files](#)

[Maximize Your AMT Webinar](#)

[ztest group](#)

---

[My Settings](#)

[Company Profile](#)

[Email Alerts](#)

[My Briefcase](#)

[My Profile](#)

---

[RSS Feeds](#)

[Sell Your Product](#) >

We want to help you sell your products by gathering the latest information on your customers. Use the links on the left to learn more about projects in different stages of development:

[Sell Now](#) for current opportunities, including type of machine, customer use, & contact information

[On the Horizon](#) for opportunities with less specific information, usually within a two year window

[Scuttlebutt](#) for opportunities that aren't clearly defined, but show promise for new business

[Current Funding Opportunities](#) for opportunities from the U.S. government & other entities

---

If you would like to have this information delivered to you via e-mail, please go to [Email Alerts](#) under My Settings and scroll down to the Sell Your Products section.

Contact a member of the [Strategic Information & Research](#) or [Business Development](#) departments if you would like further information on any of the opportunities listed.



**Login:**

**Password:**

**Login**

[Register](#)  
[Forgot Password](#)

**RSS Feeds**

**Poll**

Which public policy issue is most important to your company right now?

- Access to Credit
- Health Care Reform
- Export Control/Visa Reform
- Energy/Climate Change
- Federal R&D Support
- Defeat of Union Card Check

- Extension of Bonus Depreciation/Sec.179 Expensing Programs
- Workforce Development Programs

**Vote**

**Get Involved with AMT**

- Board of Directors
- Committees
- Product Groups

Latest Announcements

Sell Now

On the Horizon

Scuttlebutt

Current Funding Opportunities



17 December 2009

[Outlook for the Machine Tool Industry in the Current Economy - Quality Digest Interview with AMT's Pat McGibbon](#)

Raissa Carey of Quality Digest Magazine interviewed Pat McGibbon, AMT's Vice President Strategic Information and Research, on what manufacturers across the country should expect in 2010.

[\(more\)](#)

SHARE

14 December 2009

[December 14, 2009 - USMTC News Release for October Manufacturing Technology Consumption](#)

October U.S. manufacturing technology consumption totaled \$152.68 million, according to AMT - The Association For Manufacturing Technology, and AMTDA, the American Machine Tool Distributors' Association. This total, as reported by companies participating in the USMTC program, was down 2.8% from September and down 49.0% from the total of \$299.28 million reported for October 2008. With a year-to-date total of \$1,372.31 million, 2009 is down 65.9% compared with 2008. [\(more\)](#)

SHARE

11 December 2009

[Webinar Recording: Customer Service Webinar Series](#)

- A series of 4 webinars on important customer service and support principles:
- Best practices
  - Important soft skills for engineers

**AMT Meetings & Events**

**IMTS Webinar: Pre-Show Promotions**  
January 07, 2010  
Webinar

**2010 Regional Meeting in Los Angeles**  
January 15, 2010  
Los Angeles, California

**2010 Regional Meeting in Chicago**  
January 19, 2010  
Chicago, Illinois

**ANSI B11.3 Subcommittee Meeting - Power Press Brakes**  
January 19 - 21, 2010  
Longboat Key (Sarasota), Florida

**Webinar - 6 Steps to Grow Your Business in a Difficult Economy - Part 2**  
January 19, 2010  
Webinar

**2010 Regional Meeting in Detroit**  
January 20, 2010  
Detroit, Michigan

**2010 Regional Meeting in Cleveland**  
January 22, 2010  
Cleveland, Ohio

**2010 Regional Meeting in Hartford**  
January 26, 2010  
Hartford, Connecticut

**2010 Regional Meeting in Charlotte**

*A simple, clear  
message can  
be improved  
with*  
**EXPERIENCE.**



SEE. ADAPT. THRIVE.

2010 AMT REGIONAL MEETINGS

